

Pistol grip grease gun

Models 1132 and 1133

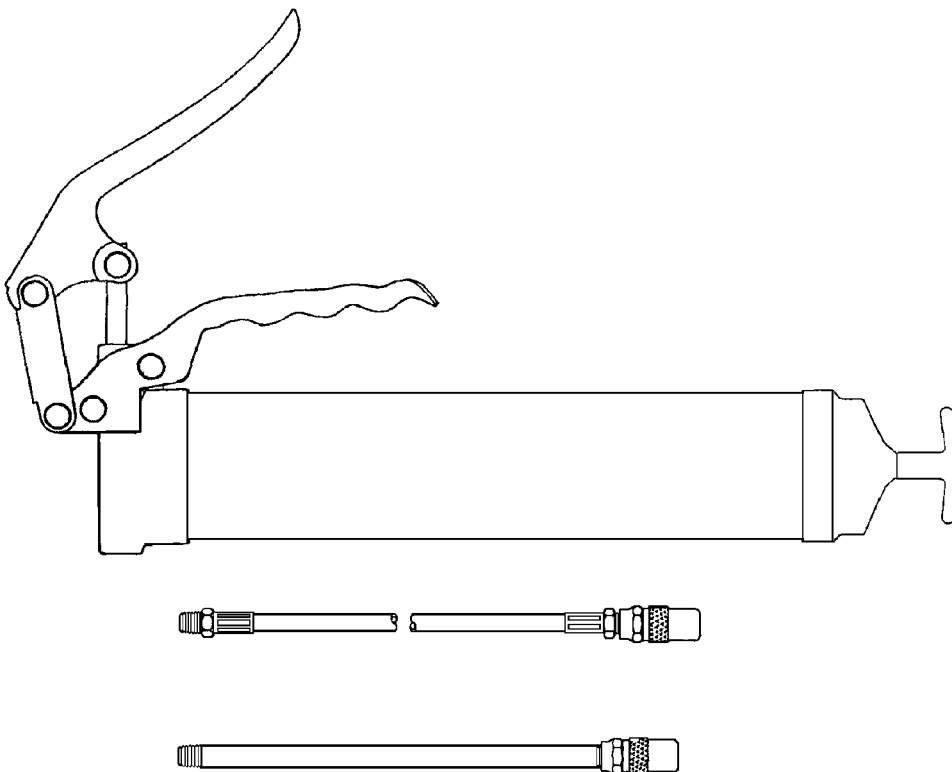

Date of issue **March 2015**

Form number **404629F**

Read manual prior to installation or use of this product. Keep manual nearby for future reference.

Table of contents

Safety 2

Capacity 3

Service parts 3

Operating instructions 4

How to install a grease cartridge 4

How to fill the grease gun from a bulk lubricant container 4

How to fill a grease gun with a filler pump 4

How to expel air pocket 5

Warranty 6

Safety

Read and carefully observe these installation instructions before installing, operating or troubleshooting the assembly. The assembly must be installed, maintained and repaired exclusively by persons familiar with the instructions.

Install the assembly only after safety instructions and this guide have been read and are completely understood.

Adequate personal protection must be used to prevent splashing of material on the skin or in the eyes.

Always disconnect power source (electricity, air or hydraulic) from the pump when it is not being used.

This equipment generates very high grease pressure. Extreme caution should be used when operating this equipment as material leaks from loose or ruptured components can inject fluid through the skin and into the body. If any fluid appears to penetrate the skin, seek attention from a doctor immediately.

Do not treat injury as a simple cut. Tell attending doctor exactly what type of fluid was injected.

Any other use not in accordance with instructions will result in loss of claim for warranty or liability.

- Do not misuse, over-pressurize, modify parts, use incompatible chemicals, fluids, or use worn and/or damaged parts.
- Do not exceed the stated maximum working pressure of the pump or of the lowest rated component in your system.
- Always read and follow the fluid manufacturer’s recommendations regarding fluid compatibility, and the use of protective clothing and equipment.
- Failure to comply may result in death or serious injury.

Explanation of signal words for safety



This is the safety alert symbol. It is used to alert you to potential physical injury hazards. Obey all safety messages that follow this symbol to avoid possible injury or death.

SAFETY INSTRUCTION

Safety instruction signs indicate specific safety-related instructions or procedures.

DANGER

Indicates a hazardous situation which, if not avoided, will result in death or serious injury.

WARNING

Indicates a hazardous situation which, if not avoided will result in death or serious injury.

CAUTION

Indicates a hazardous situation which, if not avoided, could result in minor or moderate injury.

Capacities

Bulk capacity 16 oz (473 cm³)
 Cartridge capacity 14 1/2 oz. (429 cm³)

Service parts

Item	Description	Part
1	Container packing	236989
2	Return spring	271552
3	Filler nipple ¹⁾	91108
4	Follower handle	272078*
5	Hydraulic coupler	5852
6	Hose (1133 only)	71518
7	Pipe nipple (1132 only)	67020
8	Follower assembly	93499*

¹⁾ Must be ordered separately.
 * Indicates change

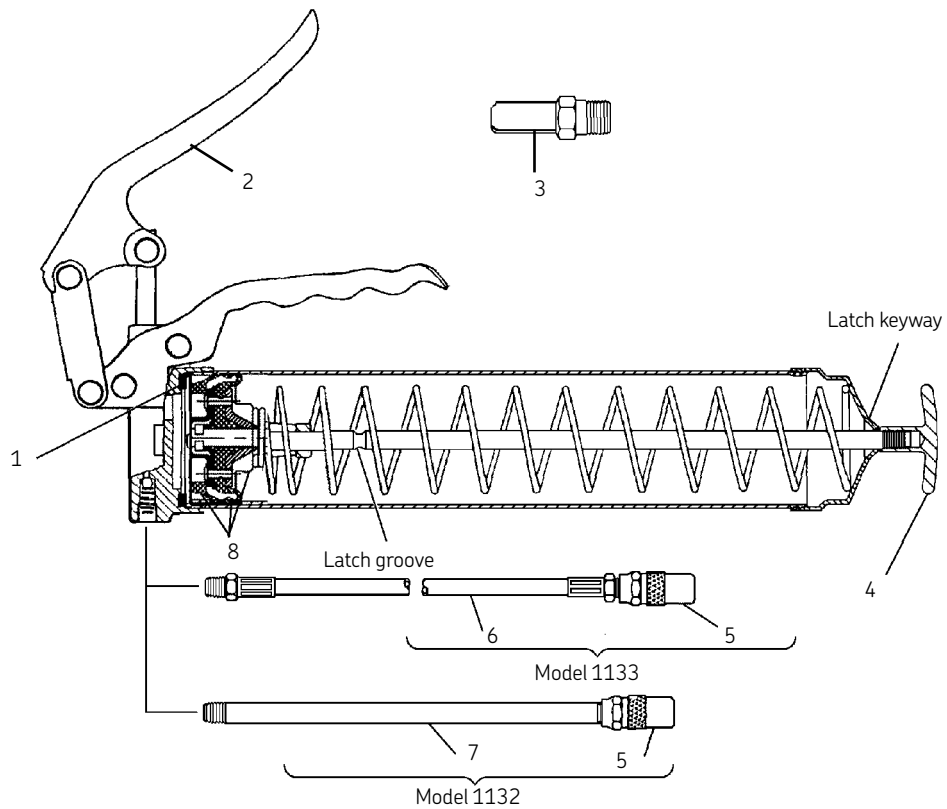

⚠ WARNING

Extreme pressure may cause nozzle extension or whip hose to burst. Use only **Lincoln approved** hoses and follow whip hose instructions and warnings.

⚠ WARNING

Use safety glasses and gloves for protection during operation. Keep hands clear of the extension during operation of the grease gun. Grease gun can develop high pressure up to 6,000 psi (413 bar).

Operating instructions

- 1 Place a grease cartridge into the container tube. See "How to install a grease cartridge" below.
- 2 Wipe all the fittings clean before lubricating.
- 3 Push the coupler onto the grease fitting at a slight angle and then center the coupler onto the grease fitting.
- 4 Squeeze the pistol grip pump handle to dispense the grease taking care not to damage seals by excessive pressure or lubricant volume
- 5 When finished lubricating, turn the coupler at a slight angle to release the coupler jaws grip

How to install a grease cartridge

- 1 Unthread the container tube from pump head 1 full turn.
- 2 Pull back the T-handle until the follower rod is fully extended, approximately 8 inches; pull it sideways to latch the rod groove into the keyhole slot in the container cap.
- 3 Remove the pump head from container tube.
- 4 Remove the plastic cap from the end of the grease cartridge and insert the open end into the container tube.
- 5 Remove the pull tab from the grease cartridge.
- 6 Loosely assemble the pump head to the container tube.
- 7 Disengage the follower rod from the container cap.
- 8 Engage the follower rod with the follower by rotating the T-handle and tap lightly to ensure the follower has entered cartridge chamber.
- 9 Squeeze pump handle while tightening the container tube into the pump head.
- 10 Disengage the follower rod from the follower by rotating the T-handle and push the follower rod into the container.

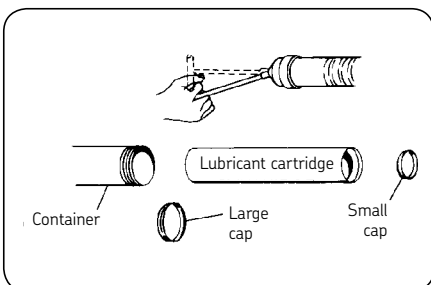

How to fill the grease gun from a bulk lubricant container

- 1 Remove the pump head from container tube.
- 2 Pack grease into the cavity of the pump head.
- 3 Insert the open end of the container tube into grease.
- 4 Slowly pull the follower handle back while pushing the container tube deeper into the lubricant to prevent air pockets from forming in the container tube.
- 5 When the follower rod is fully extended pull it sideways to latch the rod groove into the keyhole slot in the container cap.
- 6 Loosely assemble the pump head to the filled container tube.
- 7 Release the follower rod from the container cap and disengage the follower rod from the follower by rotating the follower handle.
- 8 Slowly squeeze pump handle while tightening the container tube into the pump head.

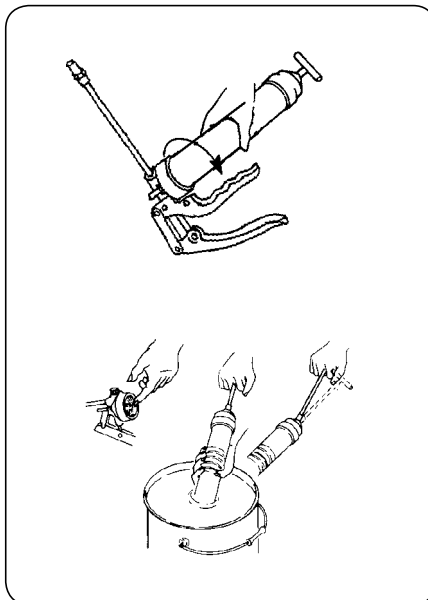

How to fill a grease gun with a filler pump

- 1 Engage the follower rod with the follower by rotating the follower handle.
- 2 Insert the grease gun filler nipple (not included) into the filler pump socket and extend the grease gun handle away from the container tube.
- 3 Operate the filler pump to fill the grease gun container. When the follower rod is fully extended to approximately 8 in. (203 mm) the container is filled
- 4 Disengage the follower rod from the follower by rotating the follower handle then push the follower rod into the container.

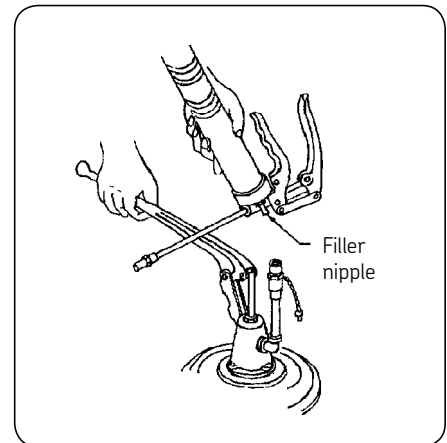

Notice*

If inspection and cleaning are not performed correctly, grease gun will lose prime and will continue to lose prime until cleaned properly.

* Indicates change

How to expel air pockets

- 1 Unscrew the container tube approximately 1 1/2 turns from the pump head assembly.
- 2 Withdraw the follower rod from the container cap and engage it with the follower by rotating the follower handle.
- 3 While exerting light force on the follower handle, squeeze the pump handle until grease appears from the coupler or between the container tube and pump head.
- 4 Retighten the container tube into the pump head.
- 5 Disengage the follower rod from the follower by rotating the follower handle.
- 6 Push the follower rod into the container.

Lincoln industrial standard warranty

Standard limited warranty

Lincoln warrants the equipment manufactured and supplied by Lincoln to be free from defects in material and workmanship for a period of one (1) year following the date of purchase, excluding there from any special, extended, or limited warranty published by Lincoln. If equipment is determined to be defective during this warranty period, it will be repaired or replaced, within Lincoln's sole discretion, without charge.

This warranty is conditioned upon the determination of a Lincoln authorized representative that the equipment is defective. To obtain repair or replacement, you must ship the equipment, transportation charges prepaid, with proof of purchase to a Lincoln Authorized Warranty and Service Center within the warranty period.

This warranty is extended to the original retail purchaser only. This warranty does not apply to equipment damaged from accident, overload, abuse, misuse, negligence, faulty installation or abrasive or corrosive material, equipment that has been altered, or equipment repaired by anyone not authorized by Lincoln. This warranty applies only to equipment installed, operated and maintained in strict accordance with the written specifications and recommendations provided by Lincoln or its authorized field personnel.

This warranty is exclusive and is in lieu of any other warranties, express or implied, including, but not limited to, the warranty of merchantability or warranty of fitness for a particular purpose. Warranty on items sold by Lincoln, but not manufactured by Lincoln are subject to the warranty consideration, if any, of their manufacturer (such as hoses, hydraulic and electric motors, electrical controllers, etc.) Assistance in making such warranty claims can be offered as required.

In no event shall Lincoln be liable for incidental or consequential damages. Lincoln's liability for any claim for loss or damages arising out of the sale, resale or use of any Lincoln equipment shall in no event exceed the purchase price. Some jurisdictions do not allow the exclusion or limitation of incidental or consequential damages, therefore the above limitation or exclusion may not apply to you.

This warranty gives you specific legal rights. You may also have other rights that vary by jurisdiction.

Customers not located in the Western Hemisphere or East Asia: Please contact Lincoln GmbH and Co. Kg, Walldorf, Germany, for your warranty rights.

Special limited warranties

Special limited 2 year warranty SL-V series, single injectors – 85772, 85782, and replacement injectors – 85771, 85781

Lincoln warrants the SL-V Injector series to be free from defects in material and workmanship for two (2) years following the date of purchase. If an injector model (single or replacement) is determined to be defective by Lincoln, in its sole discretion, during this warranty period, it will be repaired or replaced, at Lincoln's discretion, without charge.

Special limited 5 year warranty series 20, 25, 40 bare pumps, pmv bare pumps, heavy duty and 94000 series bare reels

Lincoln warrants series 20, 25, 40 bare pumps, PMV bare pumps, heavy duty (82206), mini bench (81133, 81323), and all 94000 LFR series (single arm and dual arm) bare reels to be free from defects in material and workmanship for five (5) years following the date of purchase. If equipment is determined by Lincoln, in its sole discretion, to be defective during the first year of the warranty period, it will be repaired or replaced at Lincoln's discretion, without charge. In years two (2) and three (3), the warranty on this equipment is limited to repair with Lincoln paying parts and labor only. In years four (4) and five (5), the warranty on this equipment is limited to repair with Lincoln paying for parts only.

Special limited 5 year warranty limited oil meters, limited fluid control valves, aod (air-operated diaphragm pumps)

Lincoln warrants the 712 series control valves, 912 series lube meters, electronic lube meters (980, 981, 982 series), our universal inline digital meters (812/813 series), and our AOD pump offering to be free from defects in material and workmanship for five (5) years following the date of purchase. If either is determined to be defective by Lincoln, in its sole discretion, during the warranty period, they will be repaired or replaced, at Lincoln's discretion, without charge.

Special DEF (diesel exhaust fluid) limited warranty

DEF products are warranted to be free from defects in material and workmanship for a period of one (1) year following the date of purchase. The following exceptions to the standard warranty period are in effect:

- **85700-30/85700-50 DEF hose reels (bare reel only),** 277251/277252 AC DEF pumps, and 277256 and 277257 DEF meters are warranted for two (2) years from date of purchase.
- **85623 DEF AOD (air operated diaphragm) pumps** are covered under the standard five (5) year AOD pump warranty.

If either is determined to be defective by Lincoln, in its sole discretion, during the warranty period, they will be repaired or replaced, at Lincoln's discretion, without charge.

Lincoln Industrial contact information

To find Lincoln Industrial's nearest service center call the following number; customer service 314-679-4200 (international number 01-314-679-4200) or you may also use our website www.lincolnindustrial.com
Lincoln Industrial
One Lincoln Way
St. Louis, MO 63120

This page intentionally left blank.

The Power of Knowledge Engineering

Combining products, people, and application-specific knowledge, SKF delivers innovative solutions to equipment manufacturers and production facilities in every major industry worldwide. Having expertise in multiple competence areas supports SKF Life Cycle Management, a proven approach to improving equipment reliability, optimizing operational and energy efficiency and reducing total cost of ownership.

These competence areas include bearings and units, seals, lubrication systems, mechatronics, and a wide range of services, from 3-D computer modelling to cloud-based condition monitoring and asset management services.

SKF's global footprint provides SKF customers with uniform quality standards and worldwide product availability. Our local presence provides direct access to the experience, knowledge and ingenuity of SKF people.

® SKF is a registered trademark of the SKF Group.

® Lincoln is a registered trademark of Lincoln Industrial Corp.

© SKF Group 2015

The contents of this publication are the copyright of the publisher and may not be reproduced (even extracts) unless prior written permission is granted. Every care has been taken to ensure the accuracy of the information contained in this publication but no liability can be accepted for any loss or damage whether direct, indirect or consequential arising out of the use of the information contained herein.

SKF PUB LS/I4 14055 EN · March 2015 · Form 404629F

LINCOLN

