

Automatic air grease gun

Model 1162

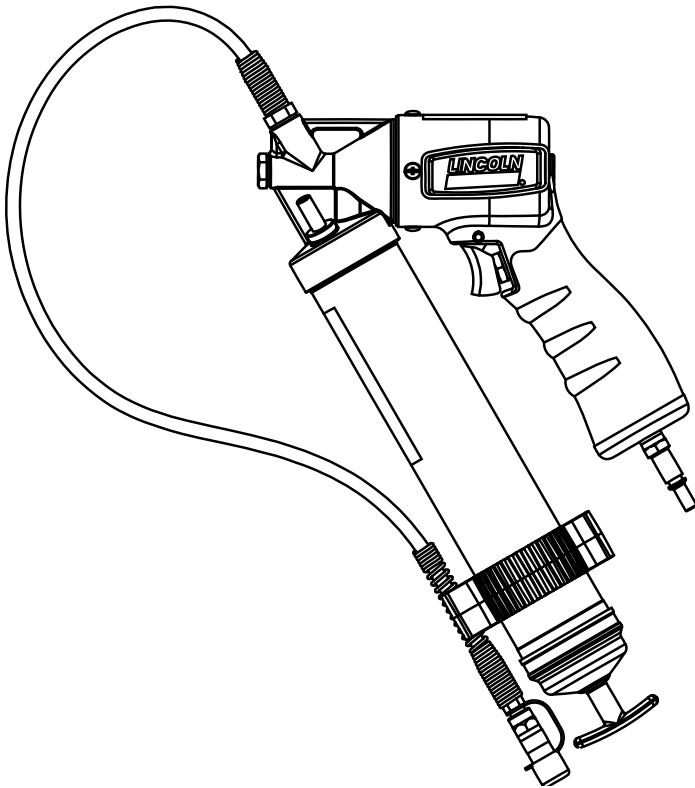

Date of issue **April 2016**

Form number **404628B**

Read manual prior to installation or use of this product. Keep manual nearby for future reference.

Table of contents

- Safety 3
- Personal Safety 3
- Description 3
- Appropriate Use 5
- Specifications 5
- Work Area 5
- Inspection 4
- Operation 4
- Removing Empty Grease Cartridge... 4
- Installation of Grease Cartridge 4
- To Convert Gun 5
- To Fill the Gun from Bulk Container... 5
- To Fill the Gun with a Filler Pump... 5
- To Expel Air Pockets 5
- Service Parts 6
- Troubleshooting 8
- Warranty 9

Safety

Read and carefully observe these installation instructions before installing, operating or troubleshooting the assembly. The assembly must be installed, maintained and repaired exclusively by persons familiar with the instructions.

Install the assembly only after safety instructions and this guide have been read and are completely understood.

Adequate personal protection must be used to prevent splashing of material on the skin or in the eyes.

Always disconnect power source (electricity, air or hydraulic) from the pump when it is not being used.

This equipment generates very high grease pressure. Extreme caution should be used when operating this equipment as material leaks from loose or ruptured components can inject fluid through the skin and into the body. If any fluid appears to penetrate the skin, seek attention from a doctor immediately.

Do not treat injury as a simple cut. Tell attending doctor exactly what type of fluid was injected.

Any other use not in accordance with instructions will result in loss of claim for warranty or liability.

- Do not misuse, over-pressurize, modify parts, use incompatible chemicals, fluids, or use worn and/or damaged parts.
- Do not exceed the stated maximum working pressure of the pump or of the lowest rated component in your system.
- Always read and follow the fluid manufacturer’s recommendations regarding fluid compatibility, and the use of protective clothing and equipment.
- Failure to comply may result in death or serious injury.

Explanation of signal words for safety



This is the safety alert symbol. It is used to alert you to potential physical injury hazards. Obey all safety messages that follow this symbol to avoid possible injury or death.



Safety instruction signs indicate specific safety-related instructions or procedures.



Indicates a hazardous situation which, if not avoided, will result in death or serious injury.



Indicates a hazardous situation which, if not avoided will result in death or serious injury.



Indicates a hazardous situation which, if not avoided, could result in minor or moderate injury.

Read and carefully observe these operating instructions before unpacking and operating the air grease gun. The gun must be operated, maintained and repaired exclusively by a person familiar with the operation instructions. Operate the gun only after safety instructions and this operation manual are fully understood.

WARNING

Extreme pressure may cause whip hose to burst. Use only Lincoln approved hoses and follow the hose instructions and warnings.

WARNING

Use safety glasses and gloves for protection during operation. Keep hands clear of the exposed rubber portion of hose. Grease gun can develop high pressure up to 6,000 psi (414 Bar).

This grease gun generates high grease pressure. Extreme caution should be used when operating the gun as material leaks from loose and ruptured components can inject fluid through the skin and into the body causing serious bodily injury. Adequate protection is recommended to prevent splashing of material onto the skin or into the eyes.

WARNING

If any fluid appears to penetrate the skin, get emergency medical immediately. Do not treat as a simple cut. Tell attending physician exactly what fluid was injected.

Personal safety

- 1 Always wear eye protection. The air grease gun can generate up to 6,000 psi (414 Bar) of pressure.
- 2 Use only Lincoln P/N 1218, 1224, 1230 or 1236 outlet whip hoses. Grease injection injuries are a very serious injury. Hold the hose only in the area of the spring guard.
- 3 Avoid accidental starting. Be sure trigger is not depressed when attaching inlet air hose.
- 4 Do not bend the hose in small radii.
- 5 Replace the hose at the first sign of wear, kink or damage to the outside jacket.

Quick start instructions

- 1 Attach high pressure grease hose and coupler (1) to outlet in the head (5). Copper gasket must be used to seal hose thread to head. Tighten securely.
- 2 Attach air coupler nipple (21) to port in bottom of handle (6) and tighten securely.
- 3 Fill grease container (→ page 6 for various options).
- 4 Prime grease gun by operating slowly until grease flows from coupler (2) (→ Operation section, page 5) for detailed priming procedure.
- 5 Adjust air pressure to grease gun as required, and gun is now ready for use.
- 6 Disconnect air supply to grease gun when not in use.

Description

Lincoln Air Operated Grease Gun is fully pneumatic operational and automatic unit. The gun was developed for manual lubrication of the grease points and has ability to stall in case of a blocked bearing, fitting or lubrication line. The gun is a positive displacement single action pump that delivers lubricant each time the plunger (13) moves forward.

The gun features a throttling trigger valve. A slight pull of the trigger (8) will cause the gun to operate slowly. As more finger force is applied to the trigger, the speed of the gun will gradually increase until maximum speed is reached with the trigger fully pulled. The maximum speed of the gun is limited to reduce the problems associated with dispensing lubricant too quickly, such as damaging bearing seals or dust boots.

The gun operates when the trigger (8) is depressed. Air is admitted to chamber A (→ fig 1) and pushes the piston (7) with the plunger (13) to the left. Vent valve B is closed. The grease, under pressure from plunger (13), opens the check valve (3) and delivers one shot of the lubricant.

When the piston (7) reaches the bypass groove C (→ fig 2) air is admitted into chamber D and opens the vent valve B. The air pressure from chamber A is vented through valve B and vent holes E to the chamber F which communicates with the atmosphere through the hole G. The air pressure is equalized on both sides of the piston (7) and the force of the spring (12) will return the piston to the initial position, recharging the gun (→ fig 1). Vent valve B will be closed and air from chamber D is vented through the bypass groove C to the atmosphere. The cycle repeats in the same manner while the trigger is depressed.

Fig. 1

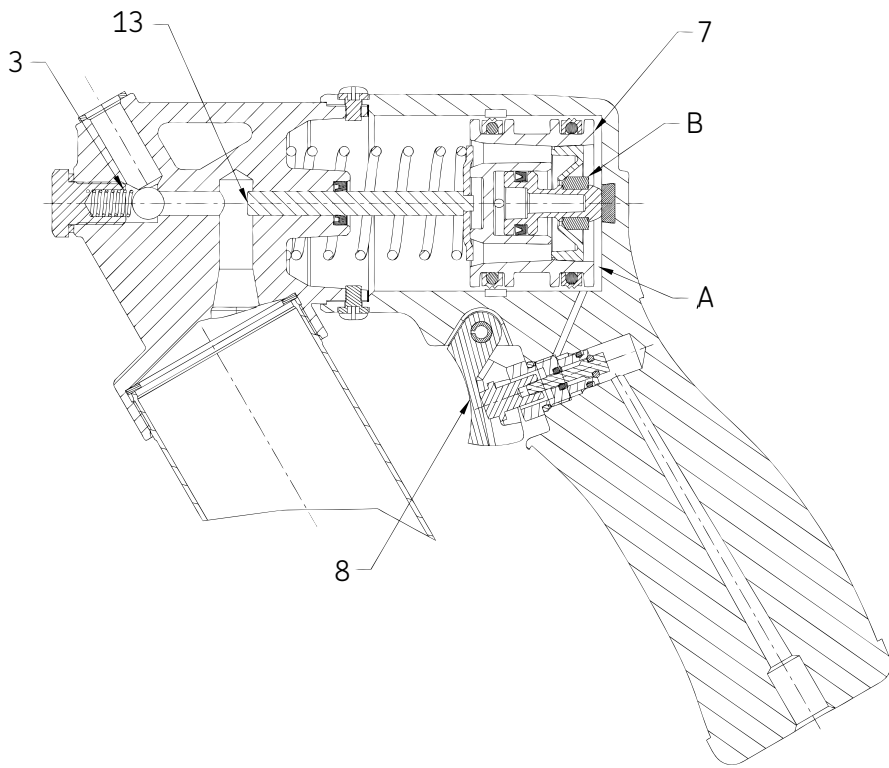
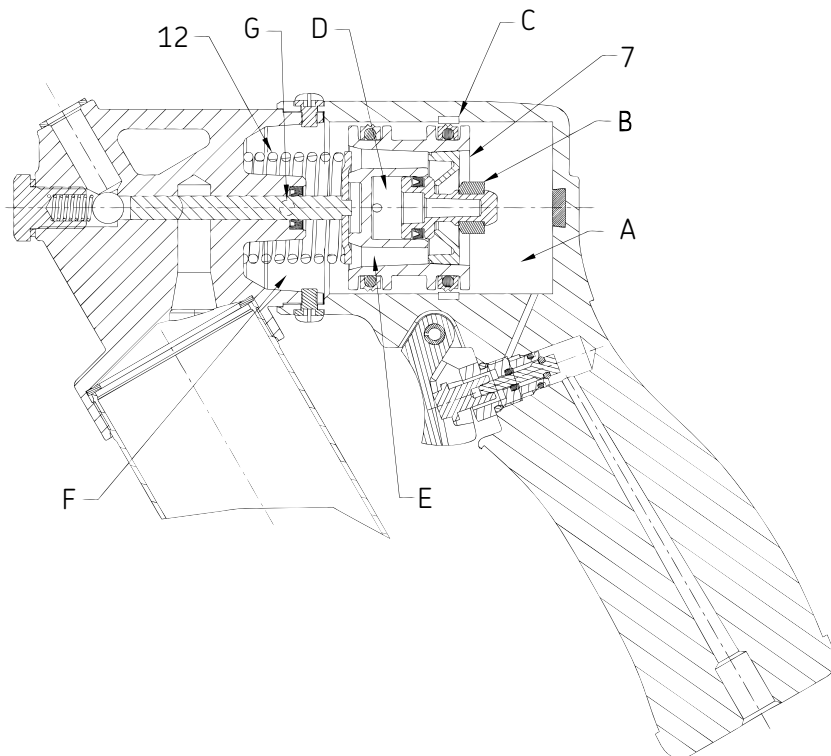

Fig. 2



Appropriate use

- The air gun was exclusively designed to pump and dispense lubricant using pneumatic power.
- The maximum specification rating should not be exceeded.
- Any other use not in accordance with instruction will result in loss of claim for warranty or liability.

Work area

Keep bystanders, children, and visitors away while operating. Distractions can cause you to make mistakes.

Inspection

Visually inspect for damaged, loose or missing parts. If equipment is worn or damaged, remove from service. Contact an authorized service center for damage assessment or repair.

Operation

Prime the air grease gun after each refill or grease cartridge change. Prime the gun before using it to lubricate grease points.

For optimum performance and product life, add a few drops of lubricating oil (SAE 30 or greater) through the air fitting at the bottom of the handle if gun begins to cycle slowly or erratically.

Specifications

Pump ratio (max)	40:1
Output per stroke	0.038 in ³ (0,62 cm ³)
Pneumatic inlet pressure (minimum)	40 psi (2,7 bar)
Pneumatic inlet pressure (maximum)	150 psi (10,3 bar)
Grease output pressure (maximum)	6,000 psi (414 bar)
Grease reservoir capacity	14.5 oz (450 cm ³)
Operating temperature range	0 to 120 °F (-18 to 50 °C)
Weight (empty)	4.5 lbs. (2,0 kg)
Weight (full)	5.5 lbs. (2,5 kg)
Lubricant	Up to NGLI #2 grease
Pneumatic port inlet	1/4-18 NPSF
Grease port outlet	7/16-28 UNEF

To prime, operate the gun slowly, by gently throttling the trigger **(8)**, until grease flows from the open end of the hose. The vent/filler valve **(18)** should be used to expel air pockets. This is done by loosening the vent/filler valve a couple of turns, holding the gun with the discharge hose pointing up, and allowing the air to escape. Close the vent/filler valve after air is removed. If a prime can not be achieved after the gun has operated for 10-15 seconds, refer to the section

To expel air pockets, page 6.

The gun will stall if a bearing or fitting is blocked, causing the grease pressure to rise to maximum. A blocked bearing or fitting should be corrected before continuing lubrication.

CAUTION

Air pockets in the cartridge lubricant will cause the gun to lose prime.

Removing empty grease cartridge

- 1 Pull back on the follower handle until the follower rod is fully extended and latch the follower rod groove into the slot on the tube cap.
- 2 Unscrew the grease tube assembly from the gun.
- 3 Carefully release the follower handle to the eject the empty cartridge from container tube.

Installation grease cartridge

- 1 Pull back on the follower handle and latch the follower rod groove into the slot on the tube cap.
- 2 Remove the plastic cap from the grease cartridge and insert cartridge into container tube.
- 3 Remove the pull tab from the grease cartridge and screw grease tube assembly into pump assembly.
- 4 Release follower rod from slot. Purge air from pump. See air purging instruction.

To fill the gun from bulk container

- 1 Remove head and plunger assembly from container tube.
- 2 Pack lubricant into cavity of the head and plunger assembly.
- 3 Insert the open end of the container tube into lubricant. Pull the follower handle back while pushing the container tube deeper into the lubricant to prevent air pockets from being pulled into the container tube.
- 4 When the follower rod is fully extended, pull it sideways to latch the rod groove into the keyhole slot in the container cap.
- 5 Loosely assemble the head and plunger assembly to the filled container tube. Release the follower rod from the container cap and disengage the follower rod from the follower by rotating the follower handle. Push the follower rod into the container. Slowly unscrew the container tube from the head and plunger assembly until lubricant oozes from the interface. Tighten container tube into the head and plunger assembly.

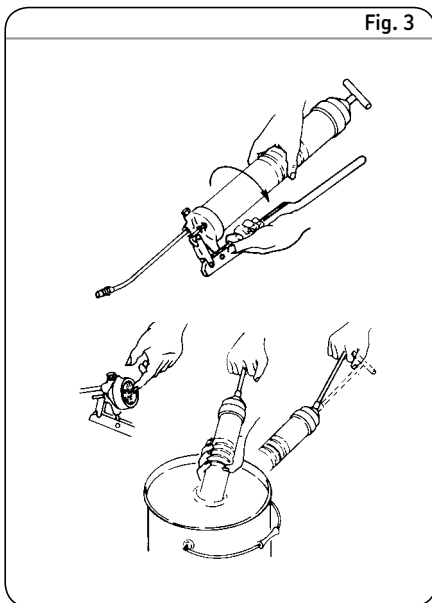

To fill the gun with a filler pump

Engage the follower rod with the follower by rotating the follower handle. Insert the gun filler nipple into the filler pump socket. Operate the filler pump to fill the container.

When the follower rod groove is exposed, the container is filled (follower rod will be extended approximately 8 in. (20 cm)). Disengage the follower rod from the follower by rotating the follower handle. Push the follower rod into the container.

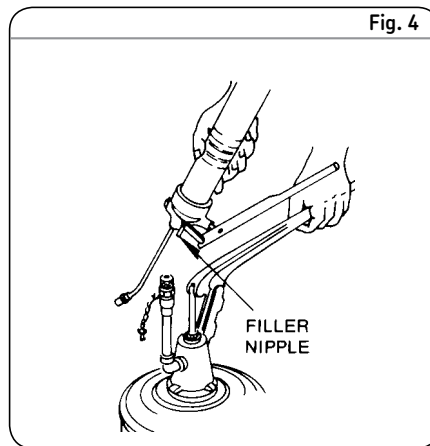

Notice*
If inspection and cleaning are not performed correctly, grease gun will lose prime and will continue to lose prime until cleaned properly.

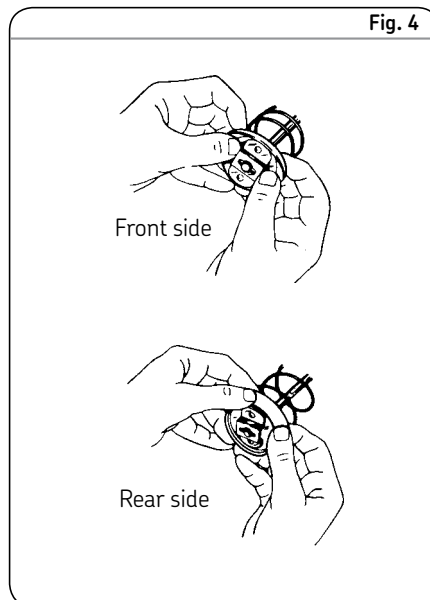

To expel air pockets

- 1 Withdraw the follower rod from the grease tube assembly cap and engage it with the follower by rotating the follower handle. Exert the force on the follower handle after opening the vent/filler fitting (18) (→ fig. 5).
- 2 Pull the trigger in short bursts to operate gun until trapped air is expelled. Disengage the follower rod from the follower by rotation the follower handle. Push the follower rod into the grease tube assembly.
- 3 If the step 2 fails, unscrew the grease tube assembly 1 1/2 turns from the pump assembly.
- 4 Exert force on the follower handle until lubricant oozes from the grease tube assembly and pump assembly interface.
- 5 Tighten grease tube assembly into the pump assembly. Disengage the follower rod from the follower by rotation the follower handle. Push the follower rod into the grease tube assembly.

To convert gun to allow filling from bulk container or filler pump*

- 1 Unscrew the container cap from the container tube. Pull on the follower handle to extract the follower and spring from the container tube.
- 2 Grasp follower between thumb and forefinger and flip the follower lip from the rear to the front side.

Notice
The follower resembles a cup. When the gun is assembled for use with bulk lubricant, the cup opens toward the head assembly.

- 3 Reassemble follower into container tube and position with the follower handle so that the container cap can be tightened onto the container tube.

* Indicates change

Fig. 5

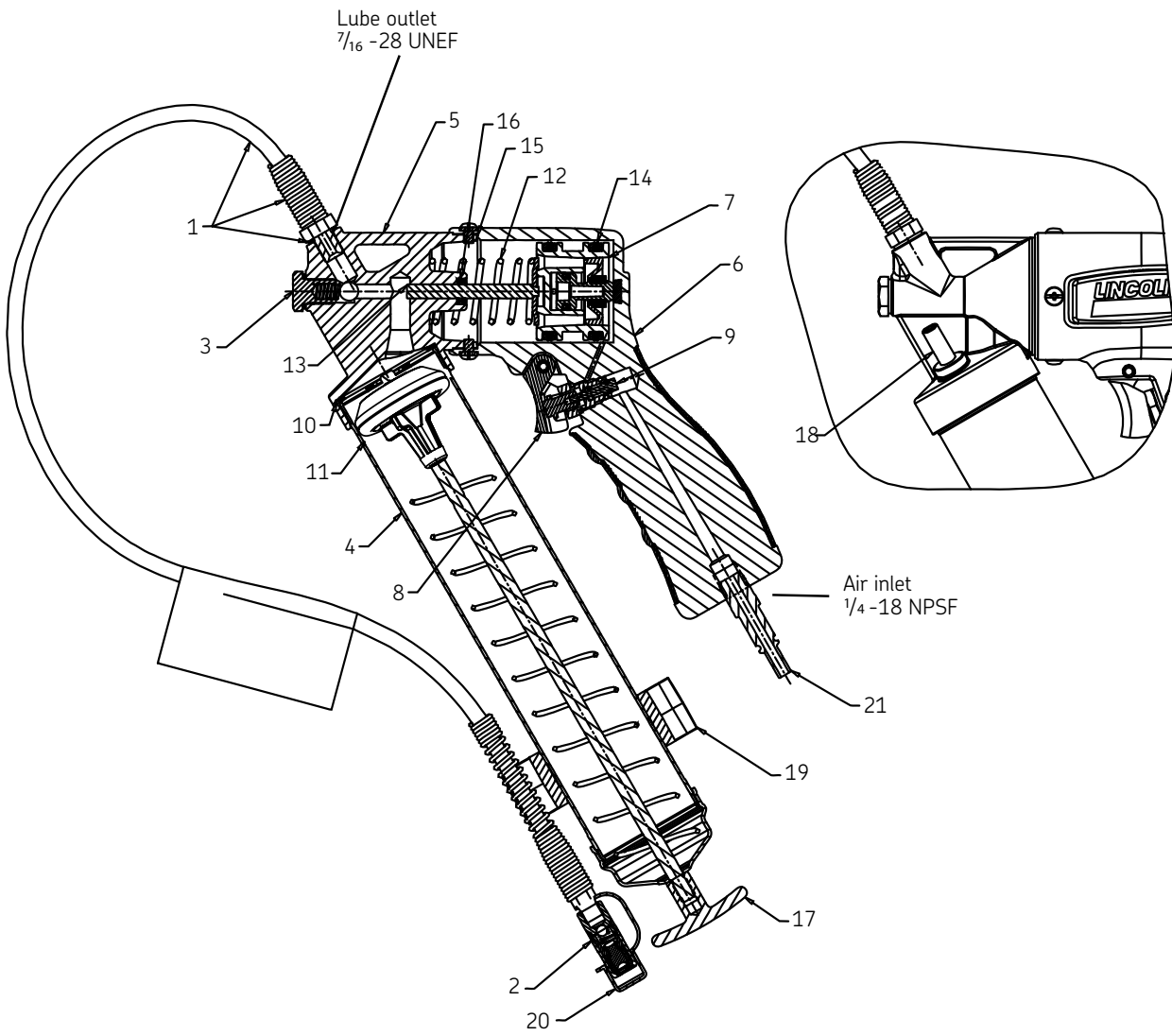

Service parts

No.	Part no.	Description	Include	Qty.
1	1230	Hose, 30 in. (762 mm)	Hose, 30 in. (762 mm) Gasket Label, warning	1 1 1
2	5852	Coupler, hydraulic	Coupler, midget	1
3	274985	Kit, outlet check	Spring housing Ball Check spring Gasket	1 1 1 1
4	277985*	Grease tube	Container assembly Label, warning	1 1
5	274984	Head	Head, machined Screw, 10-32 x 1/4 Packaging (head -tube) Gasket (handle-head) Wiper rod Valve, vent/loader	1 4 1 1 1 1
6	274983	Handle	Handle, machines Screw, 10-32 x 1/4 Gasket (handle-head) Bumper Logo, left Logo, right Name plate Handle grip	1 4 1 1 1 1 1 1
7	272068	Piston	Piston assembly Screw, 10-32 x 1/4 Gasket (handle-head)	1 4 1
8	274982	Trigger	Trigger Roll pin	1 1
9	274981	Trigger valve	Trigger valve Roll pin	1 1
10	271880	Packing	Packing	1
11	277986*	Follower	Follower assembly	1
12	272073	Spring, piston	Return Spring	1
13	274980	Plunger	Plunger assembly	1
14	272075	Crown seal	Crown seal	2
15	272076	Gasket	Gasket	1
16	272077	Wiper	Wiper rod	1
17	272078	Handle	Handle	1
18	286134	Vent/bulk valve kit	Vent/bulk valve kit	1
19	286092	Hose clip	Hose clip	1
20	286093	Coupler cap	Coupler cap	1
21	11659	Air nipple	Air nipple	1

* Indicates change

Troubleshooting

Conditions	Possible cause	Corrective action
The gun doesn't operate.	No inlet air pressure.	Connect air supply.
	The piston (7) is stuck.	Disassemble the gun, inspect for damage. Replace if necessary.
	Air pressure is too low.	Check air pressure supply. The pressure is to be higher 40 psi.
	Broken return spring (12).	Replace if necessary.
The gun doesn't operate automatically.	Air pressure is too low.	Check air pressure supply. The pressure is to be higher 40 psi.
	The piston (7) is stuck.	Disconnect air supply hose and hold on until the spring is retracted the piston back and cycle the gun. If the gun doesn't operate disassemble the gun, inspect for damage. Replace the piston if necessary.
The gun cycles but doesn't pump grease.	Loss of prime.	Repeat priming operation.
	The container is out of grease.	Check that container has grease.
	Prime is not achieved after 10 to 15 seconds of operation.	Disconnect the extension hose or rigid extension and cycle the gun until grease flows from the outlet.
The gun continues to lose prime.	Air may be trapped in several locations in container after bulk filling.	Empty container, refill and repeat priming.
	The ball check valve (3) is not functioning.	Disassemble check valve, remove ball, clean and inspect ball seat area.
If the gun still doesn't operate.		Contact an authorized service center.

Lincoln industrial standard warranty

Standard limited warranty

Lincoln warrants the equipment manufactured and supplied by Lincoln to be free from defects in material and workmanship for a period of one (1) year following the date of purchase, excluding there from any special, extended, or limited warranty published by Lincoln. If equipment is determined to be defective during this warranty period, it will be repaired or replaced, within Lincoln's sole discretion, without charge.

This warranty is conditioned upon the determination of a Lincoln authorized representative that the equipment is defective. To obtain repair or replacement, you must ship the equipment, transportation charges prepaid, with proof of purchase to a Lincoln Authorized Warranty and Service Center within the warranty period.

This warranty is extended to the original retail purchaser only. This warranty does not apply to equipment damaged from accident, overload, abuse, misuse, negligence, faulty installation or abrasive or corrosive material, equipment that has been altered, or equipment repaired by anyone not authorized by Lincoln. This warranty applies only to equipment installed, operated and maintained in strict accordance with the written specifications and recommendations provided by Lincoln or its authorized field personnel.

This warranty is exclusive and is in lieu of any other warranties, express or implied, including, but not limited to, the warranty of merchantability or warranty of fitness for a particular purpose. Warranty on items sold by Lincoln, but not manufactured by Lincoln are subject to the warranty consideration, if any, of their manufacturer (such as hoses, hydraulic and electric motors, electrical controllers, etc.) Assistance in making such warranty claims can be offered as required.

In no event shall Lincoln be liable for incidental or consequential damages. Lincoln's liability for any claim for loss or damages arising out of the sale, resale or use of any Lincoln equipment shall in no event exceed the purchase price. Some jurisdictions do not allow the exclusion or limitation of incidental or consequential damages, therefore the above limitation or exclusion may not apply to you.

This warranty gives you specific legal rights. You may also have other rights that vary by jurisdiction.

Customers not located in the Western Hemisphere or East Asia: Please contact Lincoln GmbH and Co. Kg, Walldorf, Germany, for your warranty rights.

Special limited warranties

Special limited 2 year warranty SL-V series, single injectors – 85772, 85782, and replacement injectors – 85771, 85781

Lincoln warrants the SL-V Injector series to be free from defects in material and workmanship for two (2) years following the date of purchase. If an injector model (single or replacement) is determined to be defective by Lincoln, in its sole discretion, during this warranty period, it will be repaired or replaced, at Lincoln's discretion, without charge.

Special limited 5 year warranty series 20, 25, 40 bare pumps, pmv bare pumps, heavy duty and 94000 series bare reels

Lincoln warrants series 20, 25, 40 bare pumps, PMV bare pumps, heavy duty (82206), mini bench (81133, 81323), and all 94000 LFR series (single arm and dual arm) bare reels to be free from defects in material and workmanship for five (5) years following the date of purchase. If equipment is determined by Lincoln, in its sole discretion, to be defective during the first year of the warranty period, it will be repaired or replaced at Lincoln's discretion, without charge. In years two (2) and three (3), the warranty on this equipment is limited to repair with Lincoln paying parts and labor only. In years four (4) and five (5), the warranty on this equipment is limited to repair with Lincoln paying for parts only.

Special limited 5 year warranty limited oil meters, limited fluid control valves, aod (air-operated diaphragm pumps)

Lincoln warrants the 712 series control valves, 912 series lube meters, electronic lube meters (980, 981, 982 series), our universal inline digital meters (812/813 series), and our AOD pump offering to be free from defects in material and workmanship for five (5) years following the date of purchase. If either is determined to be defective by Lincoln, in its sole discretion, during the warranty period, they will be repaired or replaced, at Lincoln's discretion, without charge.

Special DEF (diesel exhaust fluid) limited warranty

DEF products are warranted to be free from defects in material and workmanship for a period of one (1) year following the date of purchase. The following exceptions to the standard warranty period are in effect:

- **85700-30/85700-50 DEF hose reels (bare reel only),** 277251/277252 AC DEF pumps, and 277256 and 277257 DEF meters are warranted for two (2) years from date of purchase.
- **85623 DEF AOD (air operated diaphragm) pumps** are covered under the standard five (5) year AOD pump warranty.

If either is determined to be defective by Lincoln, in its sole discretion, during the warranty period, they will be repaired or replaced, at Lincoln's discretion, without charge.

Lincoln Industrial contact information

To find Lincoln Industrial's nearest service center call the following number; customer service 314-679-4200 (international number 01-314-679-4200) or you may also use our website www.lincolnindustrial.com

This page left intentionally blank

® SKF is a registered trademark of the SKF Group.

® Lincoln is a registered trademark of Lincoln Industrial Corp.

© SKF Group 2016

The contents of this publication are the copyright of the publisher and may not be reproduced (even extracts) unless prior written permission is granted. Every care has been taken to ensure the accuracy of the information contained in this publication but no liability can be accepted for any loss or damage whether direct, indirect or consequential arising out of the use of the information contained herein.

SKF PUB LS/l1 14139 EN · April 2016 · Form 404628B

LINCOLN

